

# REGULATED D.C. POWER SUPPLY

## USER MANUAL

---

---

### CONTENTS

- 1.INTRODUCTION..... 1
- 2.PRODUCTION MODELS ..... 2
- 3.SPECIFICATIONS ..... 3
  - 3-1 General..... 3
  - 3-2 Specifications..... 4
- 4.PANEL CONTROLS AND INDCATORS..... 6
  - a. 30V3A/30V5A/60V3A Front panel..... 6
  - b. 30V3A/30V5A/60V3A Rear Panel..... 6
  - c. 60V5A/30V10A Front Panel..... 7
  - d. 60V5A/30V10A Rear Panel..... 8
  - 4-1 Front Panel..... 9
  - 4-2 Rear Panel..... 10
- 5.OPERATION INSTRUCTIONS..... 11
  - 5-1 Precaution..... 11
  - 5-2 Setting Current Limit ..... 11
  - 5-3 Setting Constant Voltage ..... 12
- 6.MAINTENANCE ..... 13

## 1.INTRODUCTION

Regulated DC power supply are designed to provide the required in laboratory, university and production lines.

The output voltage is continuously adjustable between 0 to rating voltage. The load current may have any value from 0 to rating current. Voltage and Current are adjusted by means of a coarse and fine potentiometer. Both outputs can accurately read on voltmeter and ammeter.

Both stability and ripple are extremely good to meet the requirements of modern circuit design. The unit can be used as either constant voltage or current source. It has output standby function (optional), fixed DC 5V/1A output (optional). Four digital LED display (optional). Overload protection circuits.

Unit can continuously working over 8 hours with full load.

1

## 2.PRODUCTION MODELS

Ltem	Model	Output Voltage	Output Current	Output Standby	Fixed 5V/1A
1		0-30V	3A	●	
2		0-30V	3A	●	●
3		0-30V	5A	●	
4		0-30V	5A	●	●
5		0-60V	3A	●	
6		0-60V	3A	●	●
7		0-30V	10A	●	
8		0-60V	5A	●	

### 3.SPECIFICATIONS

#### 3-1 General

Main Supply: 110/220V±10%, 50/60Hz Switch selectable (customer optional)

Operation Temperature & Humidity 0°C to 40°C, <80%

Storage Temperature & Humidity -10°C to 70°C, <70%

#### Accessories

Power cord..... 1

Operation Manual..... 1

3

#### 3-2 Specifications

Model	0-30V/5A	0-30V/3A	
Constant Voltage Operation			
Line regulation	CV≤0.01%+3mV	≤0.01%+3mV	
Load regulation	CV≤0.02%+5mV	≤0.01%+3mV	
Riple & Noise	CV≤1mV(rms)	≤1mV(rms)	
Temperature coefficient	300ppm/°C		
Constant Current Operation			
Line regulation	CC≤0.2%+3mA		
Load regulation	CC≤0.2%+3mA		
Temperature coefficient	500ppm/°C		
Fixed 5V/1A Output:			
Voltage accuracy	±1%		
Riple & Noise: CV	≤2mV(rms)		
Display accuracy:	Three LED≤1%+2d		
Recover time	≤100μ S		

### 3-2 Specifications (continuance)

Model	0-30V/10A	0-60V/3A	0-60V/5A
<b>Constant Voltage Operation</b>			
Line regulation	$CV \leq 0.01\% + 5mV$		
Load regulation	$CV \leq 0.02\% + 5mV$		
Riple & Noise	$CV \leq 2mV(rms)$		
Temperature coefficient	300ppm/°C		
<b>Constant Current Operation</b>			
Line regulation	$CC \leq 0.2\% + 3mA$		
Load regulation	$CC \leq 0.2\% + 5mA$		
Riple & Noise	$CC \leq 3mA$		
Temperature coefficient	500ppm/°C		
Display accuracy:	Three LED $\leq 1\% + 2d$		
Recover time	$\leq 100 \mu S$		

5

## 4. PANEL CONTROLS AND INDICATORS

a. 30V3A/30V5A/60V3A Front panel:

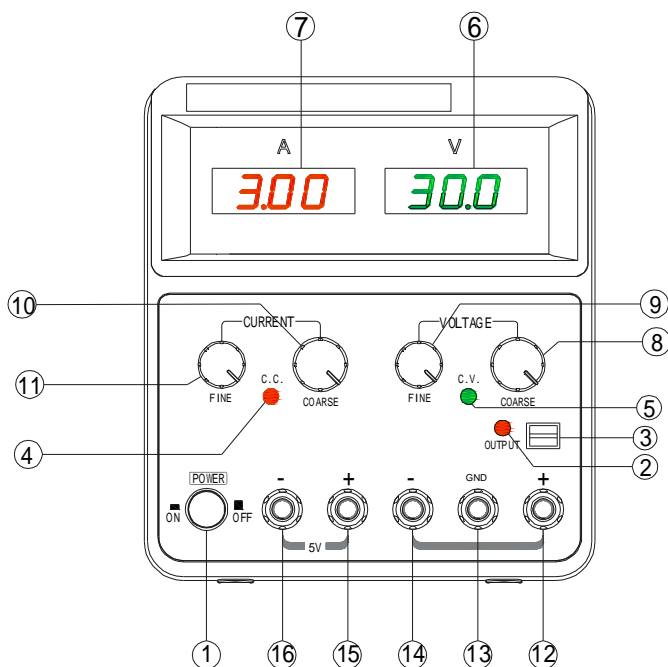

b. 30V3A/30V5A/60V3A Rear Panel:

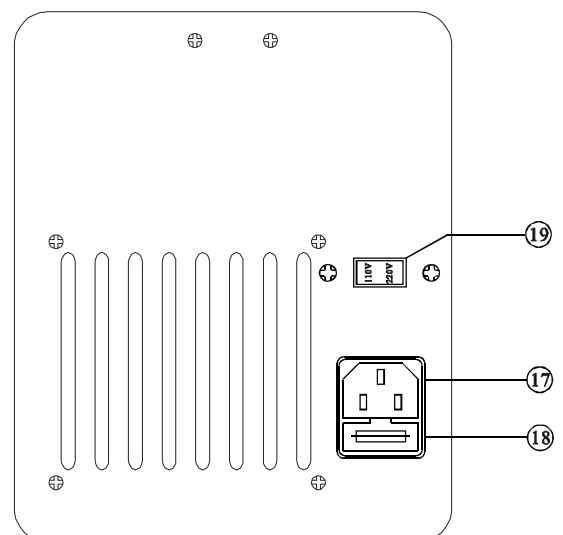

c.60V5A/30V10A Front Panel Controls and Indicator:

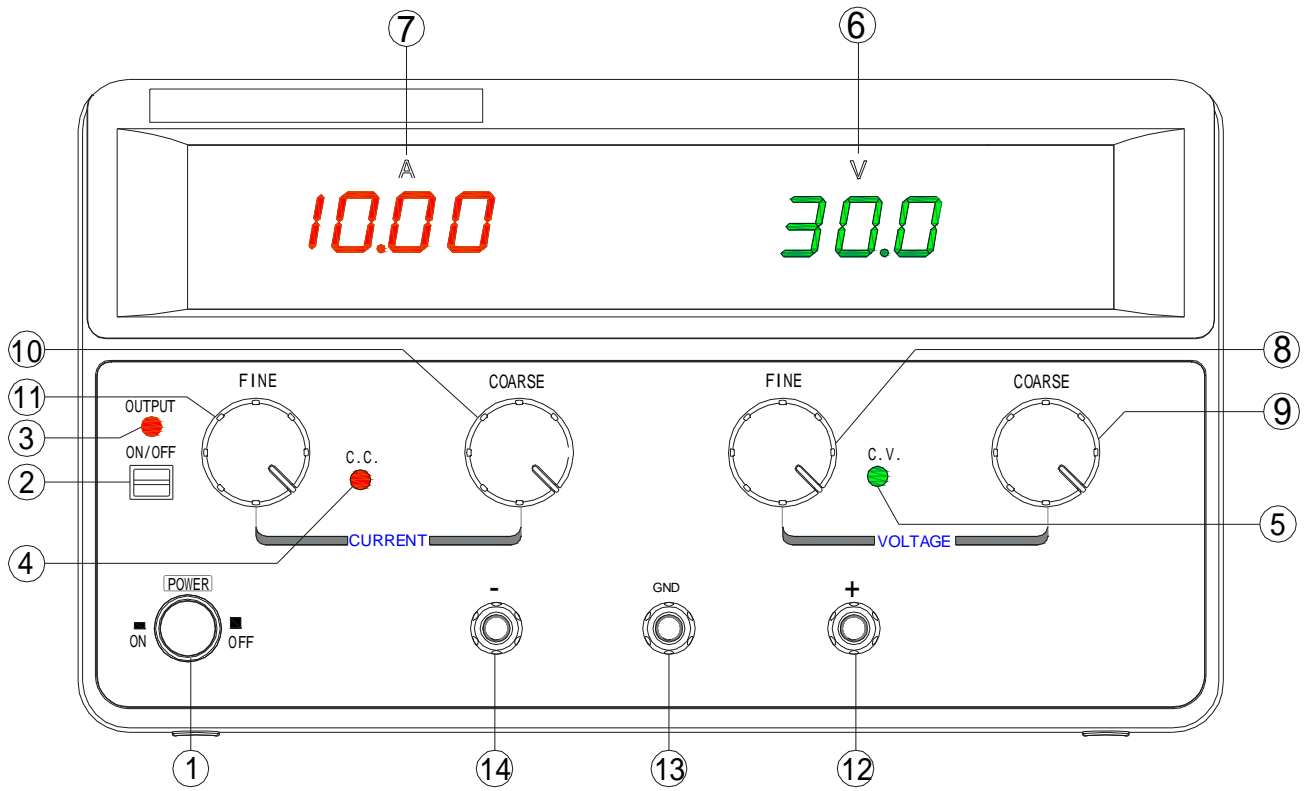

7

d.60V5A/30V10A Rear Panel Indicator

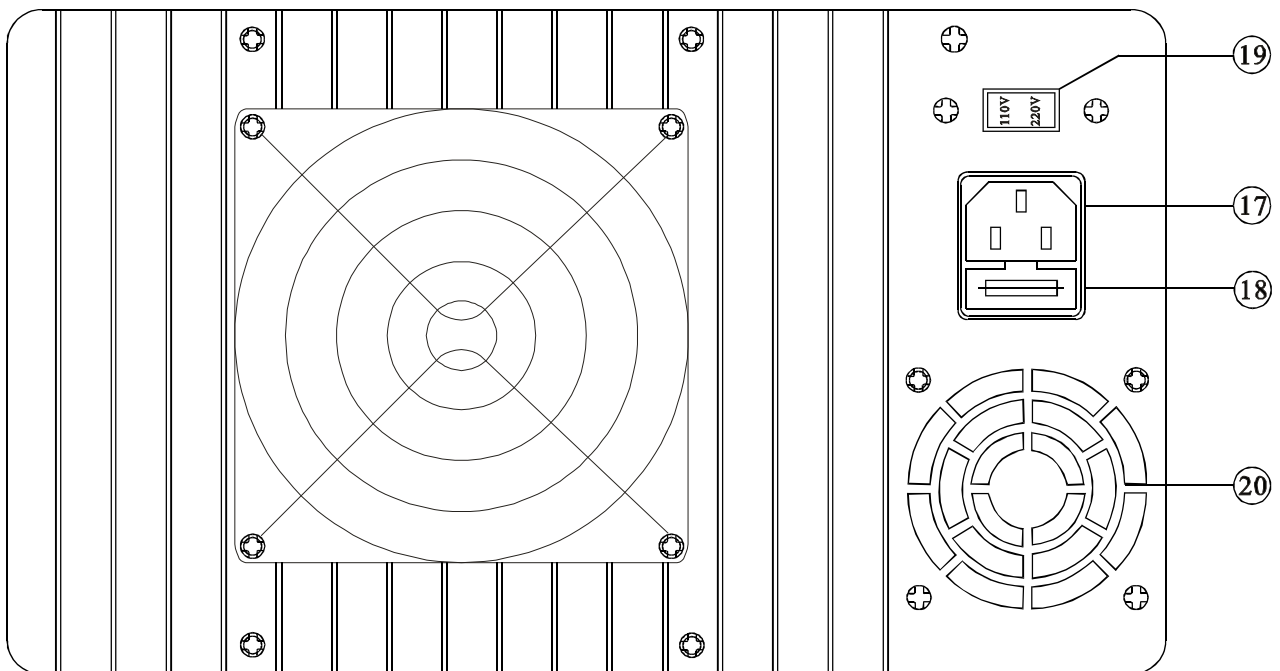

#### 4-1 Front Panel

- 1 Power switch: ON/OFF the power
- 2 Output standby: After power on, there are no voltage cross the terminals.  
Press this button, output LED on, unit has power out.Repress this  
button, output LED off, output voltage cross the terminals is zero, unit is on  
standby mode.
- 3 Output standby indicator: see above.
- 4 C.C. indicator: lights when the supply is in the constant current operation.
- 5 C.V. indicator: lights when the supply is in the constant voltage operation.
- 6 Voltmeter: Indicates the output voltage.
- 7 Ammeter: Indicates the output current.
- 8 Voltage Coarse: for coarse adjustment of the output voltage.
- 9 Voltage Fine: for fine adjustment of the output voltage.
- 10 Current Coarse: for coarse adjustment of the output current.
- 11 Current Fine: for fine adjustment of the output current.
- 12 "+" Output terminal: positive polarity
- 13 "GND" terminal: earth and chassis ground
- 14 "-" Output terminal: negative polarity
- 15 Fixed 5V/1A "+" output terminal
- 16 Fixde 5V/1A "-"output terminal

9

#### 4-2. Rear panel

17 Power Socket

18 Fuse holder

19 AC selects switch:  
(customer optional)                      The power transformer is designed to permit operation in  
110V (115V/120V) or 220V (230V/240V),50/60Hz line voltage.  
To convert from one line voltage to another is done by change  
AC selector as shown in page 8.

20 Fan

## 5. Operation instructions

### 5-1 Precaution

- 1 AC input of DC power supply should be within the range of line voltage  $220 \pm 10\%$  50Hz.  $110 \pm 5\%$  60Hz
- 2 To avoid electrical shock, the power cord protective grounding conductor must be connected to ground.
- 3 Do not use the unit in a place where ambient temperature exceeds 40°C. The heat sink located at rear of the supply must have sufficient air space for radiation.
- 4 This unit is a float DC power supply. If the output have to connected to ground, please short the "+" or "-" terminal to "GND" .

### 5-2 Setting Current Limit

- 1 Determine the maximum safe current for the device to be powered
- 2 Temporarily Short the "+" and "-" terminals of the power supply together with a test lead.
- 3 Rotated the COARSE VOLTAGE control away from zero sufficiently for the CC indicator to light.
- 4 Readr the current value on the Ammeten, Adjust the CURRENT control for the desired current limit.
- 5 The current limit (overload protection) now has been preset. Do not change the CURRENT control setting after this step.
- 6 Remove the short lead between the "+" and "-" terminals.

11

### 5-3 Setting Constant Voltage

- 1 Turn the power switch on, the CV indicator light.
- 2 Rotating the Coarse and Fine voltage control to the desired volts.
- 3 Press Output standby button, the output standby indicator light, then the terminals have voltage output.
- 4 For the models which do not have output standby function, the output voltage will supplied cross terminals immediately after power on.

## 6. MAINTENANCE

### WARNING

The following instructions are for use by qualified personnel only. To avoid electrical shock, do not perform any servicing other than contained in the operating instruction unless you are qualified to do so.

6-1 If the fuse blows, the CV or CC indicators will not light and the power supply will not operate. The fuse should not normally open unless a problem has developed in the unit. Try to determine and correct the cause of the blown fuse, then replace only with a fuse of the correct rating and type.

The fuse is located on the rear panel.

#### **When line voltage are changed, replade the required fuse shown on page 10**

6-2 In constant voltage mode, if the output voltage is less than presetted value and CC indicator light, it is over current protection. Unit automatically changed to constant current mode. Should check the load or increase current set value depends on the situation.

6-3 In constant current mode, if the output current is less than presetted value and CV indicator light, the unit automatically changed into constant voltage mode. Should check the load or increase the presetted voltage value.

6-4 If the output voltage is unstableness, please check the AC line it may less than 198V/105V.



